



Granutech-Saturn Systems

*Let the System
Work for You*

*Complete turnkey
solutions for reducing
scrap tires to high-quality
crumb rubber.*

The System is the Solution

The industry's only complete processing systems turn whole scrap tires into high value crumb rubber.

Primary Shredding

Primary shredding, the initial step in the size reduction process, reduces whole tires to strips of approximately 2-inches by 8-inches in preparation for further reduction in a Grizzly Grinder. Saturn HT Series Shredders — the most widely used tire shredder in operation today — utilize a patented anti-jam reversal design for maximum process efficiency and excel at processing a full range of tires.

Secondary Processing

The Grizzly Grinder represents the most significant improvement in granulator technology in more than a decade. Effective at reducing primary shreds to minus 3/4-inch sizes (sizes can be varied through a simple screen change), the Grizzly offers a wealth of additional benefits including dramatic improvements in granulator blade wear — often as much as 300%. Granulator throughputs are also positively impacted and, in many cases, granulators can be eliminated altogether.

Primary Granulation

Tire chips are fed, via conveyor, into a Granutech-Saturn Systems Granulator where they are reduced to minus 1/4-inch size. From there, material undergoes an initial phase of fiber aspiration and secondary magnetic separation. Additional processing further separates both large fiber and fine contaminants. Material is then routed, via enclosed conveyor, either to storage bins to undergo additional reduction or to the bagging station where it is packaged for a broad range of granular applications, including playground and agricultural use. All operational facets of the Granutech-Saturn System are easily controlled through an integrated touch-screen Programmable Logic Controller.

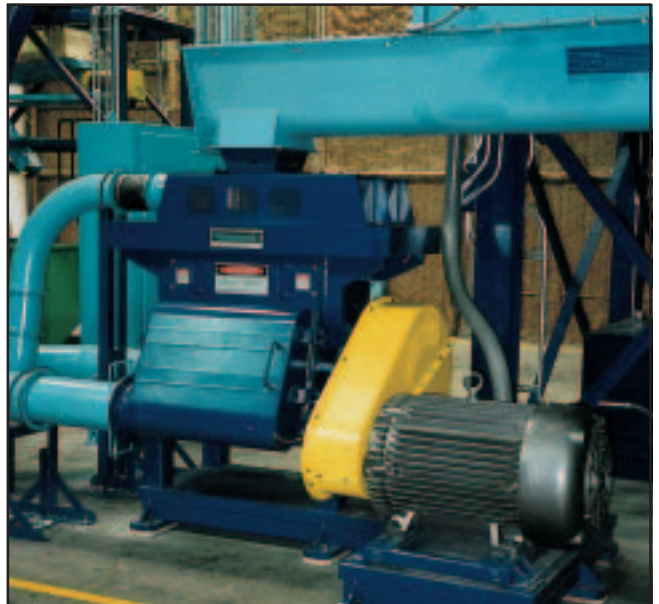

(Top) Initial processing draws upon the proven strengths and performance of Saturn's HT Series Shredder and the Grizzly Grinder for primary and secondary size reduction.

(Center) Unique rotor design and improved airflow characteristics dramatically lower internal product temperatures, virtually eliminating thermal degradation of material in the granulation process.

(Bottom) System versatility extends to final granulation. Depending upon process needs, high output powderizers can be run in series, in parallel, or independently, resulting in true process flexibility.

Final Processing

High output powderizers take material down to a wide range of sizes, including minus 1/8-inch (3mm) to +10 mesh, minus 10 mesh to +30 mesh, and minus 30 mesh to +60 mesh with use of our optional "fine grind" package. After either of these processes, additional steps, including fibre aspiration and size classification, are taken to ensure the highest quality product possible.

Custom Material Preparation

Increasingly, today's highly competitive market demands custom product blends — blends which tax the versatility of most processing systems. Equipment from Granutech-Saturn Systems affords unparalleled levels of blending options, providing ease of applicability to the widest possible range of programs and projects.

Optional state-of-the-art bagging equipment extends versatility to the packaging facet of any operation. Flexibility of packaging choices — in a host of pre-selected sizes up to "super-sacks" — provides added convenience, improves accuracy, and enhances product shipment and handling.



(Left) Product can be gathered from any number of process bins and custom-blended to meet specific end-product needs. Blended material is then electronically weighed and automatically bagged in a wide range of available bag sizes.

Granutech-Saturn is the Answer

*Put decades of experience addressing
scrap tire problems to work for you.*

Reliability is the Reason

*State-of-the-art design and
manufacturing technology provide
unparalleled reliability.*

Performance is the Result

*Your key to higher throughputs,
lower maintenance and better
accessibility to new markets.*

Every scrap tire processing operation is unique in its demands, its needs, its requirements. Tapping into Granutech-Saturn Systems means drawing upon decades of scrap tire processing expertise. The result is the highest quality full-capability system possible and an unmatched level of system support before, during and after the sale.

Starting with the primary shredder and continuing through the granulation equipment, every component of every Granutech-Saturn System is built for the long haul. The impressive track record of Saturn's HT Series shredders — the industry's highest percentages for online reliability and performance — bears that out. The latest in design, material selection and manufacturing techniques ensure that your system provides you with the results you want for high-quality crumb rubber — when you want them

What all this means is very basic: Granutech-Saturn Systems perform at a level unmatched in the industry today. The latest in controller technology and custom software design afford ease of use across every facet of the processing system. Specialized blade designs and materials employed throughout the system ensure maximum blade life, minimum downtime and higher product quality. In addition, all Granutech-Saturn Systems utilize vacuum pneumatic conveying technology to minimize product losses and maintain a clean operating environment.

For information on the industry's most comprehensive scrap tire processing capability, call Granutech-Saturn Systems today.

Mid-Stream Processing: the Grizzly is a Beast.

To further improve performance, reduce granulator wear and improve throughputs, many applications can benefit from mid-stream processing — that point in the process after the primary shred and before granulation. To make this all happen, Granutech-Saturn Systems offers the Grizzly.

A single-rotor grinder, the Grizzly has proven successful in more than doubling throughputs in a number of scrap tire applications.



The Grizzly: A Look Inside

Superb design affords the widest range material processing of its type in operation today.

Unique rotor construction and proprietary blade material allow greatest size reduction while minimizing blade wear.

Smaller, more uniform material improves performance of downstream equipment or, in many cases, replaces such equipment altogether.

300-400 hp drive systems available.

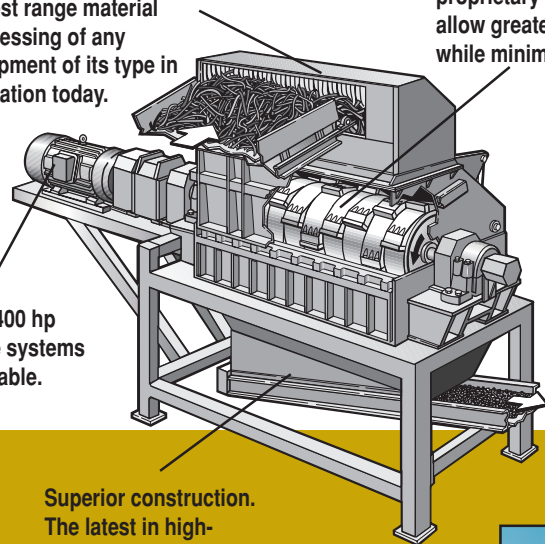

Superior construction. The latest in high-strength materials are used to ensure long life and minimal downtime.

Shown here at our Grand Prairie, Texas, test facility, the Grizzly uses air evacuation to ensure optimum separation of processed material and impurities.

The performance-based benefits don't stop there however — other factors are impacted as well. For example, taking material down to a uniform size improves magnetic separation capability. The results of that improvement are a product that is consistently better than 95% free of all steel and an enhanced level of granulator efficiency. Granulator blade life, by nature of the cleaner material being fed to it, has been shown to increase by as much as 300%.

The Grizzly can be configured, through adjustment in screen size, to create product in 1/2-inch minus, 3/4-inch minus, 1-inch minus or larger sizes.

As with any material processing operation, throughputs will vary according to specific operational demands and process stream.



The Big Picture:

MAC Corporation, Saturn Shredders and Granutech-Saturn Systems

Solutions Across the Spectrum

Granutech-Saturn Systems and its divisions, MAC Corporation and Saturn Shredders, offer the highest quality equipment and systems for size reduction of both standard and problematic materials. These include scrap tires and other rubber products, plastic and plastic by-products, wood waste, medical waste and more.



▲ Saturn HT Series Shredder

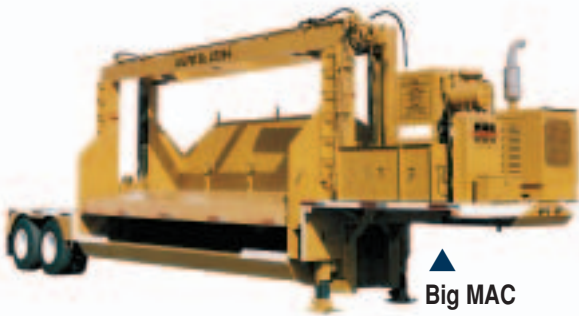

▲ Big MAC Auto Flattener

With a product line that includes “Big MAC” auto flatteners, MAC Balers, Saturn Shredders in more than a dozen sizes, the Granutech-Saturn Systems products covered here, and the expertise to design, specify, manufacture and assemble full turnkey processing systems, MAC Corporation leads the way in comprehensive solutions across the broadest range of the processing spectrum.

Roto-Grind

The newest addition to the Granutech-Saturn Systems product line, Roto-Grind shredders take a broad range of materials and quickly and efficiently shred and size them. The result is a better product — ready for subsequent processing or shipment. Using state-of-the-art single-rotor technology, Roto-Grind shredders have proven invaluable in processing plastics, wood waste, electronic scrap, cable & wire, and more. Benefits include:



- **Maximized volume reductions**
- **A fraction of the power consumption and noise generally associated with other similar processing equipment**
- **Ideal for use in waste to energy operations**
- **Virtual hands-free operation**
- **Dramatic improvements in performance of downstream equipment.**

*Simple, fast, effective size reduction in a wide range of applications.
It's what Granutech-Saturn Systems is all about.*



GRANUTECH
SATURN
SYSTEMS

Granutech-Saturn Systems Corporation

201 East Shady Grove Road

Grand Prairie, TX 75050

Toll Free: (877) 582-7800 • Phone: (972) 790-7800 • Fax: (972) 790-8733

Web: www.granutech.com • E-mail: sales@granutech.com